

Specifications

Virtually fits in a 7-inch cube!

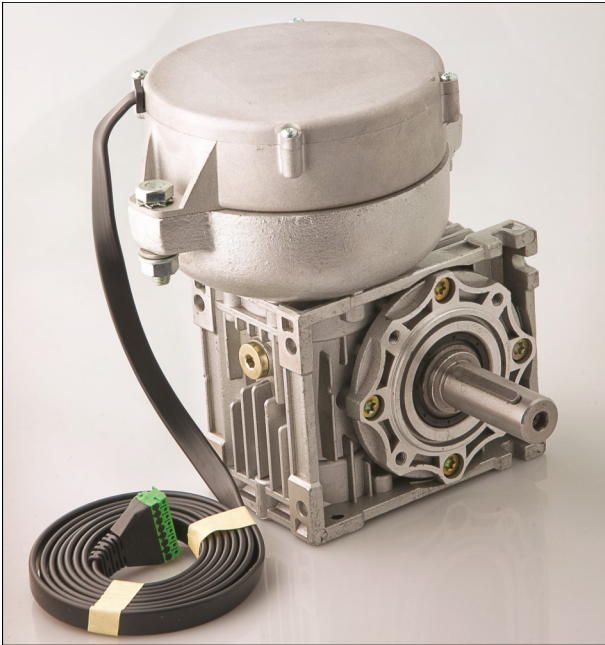

ACG's PowerCube™ is a special version of our quiet, long-life UniDrive® Brushless 24VDC motor coupled to a compact and powerful right angle gear reducer.

The PowerCube™ Drive Operational Modes:

Basic Motor:

Usable as a standalone drive with the UniDrive® SCC-3 Hi Performance control in the *Basic Motor* setting, it allows simple external control of motor run (on/off), direction, and braking.

Smart Conveyor:

In the *Smart Conveyor* Control setting, it can be used to drive Zero Pressure Accumulation conveyors without requiring PLC or computer control, but easily interfaces with either at decision points such as an exit onto other equipment. It's your best value in compact and powerful drive alternatives.

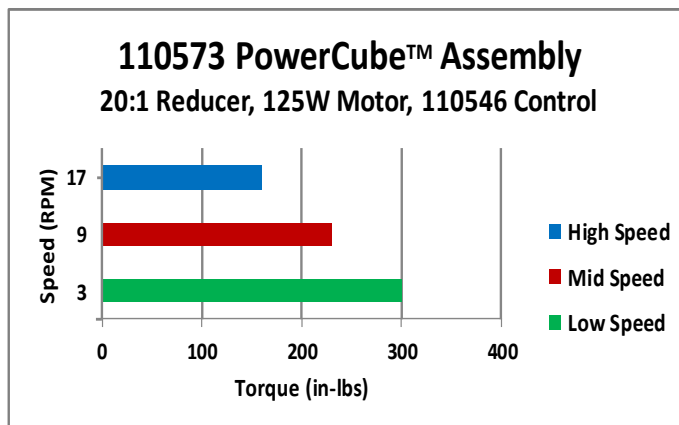

5855 N. Glen Park Road ♦ Milwaukee, WI 53209
Sales@AutomationControlsGroup.com ♦ Tel (619) 677-6530

10573A02M Rev. 4.1

PowerCube™ 24VDC Drive

110573

Brushless DC Motor/Reducer

125 Watt motor with 20:1 Reducer

Features and Specifications

The PowerCube™ Drive provides a P³ solution by integrating three innovative products from a single source that are easy to apply and use.

P¹ – 125 Watt 24 VDC UniDrive® Brushless Motor

- Exceptionally Long Life
- Naturally Low Speed and High Torque
- Low Noise
- High Reliability

P² – UniDrive® Motor Control

- Easily Preset One of 8 Speeds Over a 20:1 Range or;
- Provide a 0-10 VDC Input for Dynamic Speed Control (P/N: 300128 Module can be used)
- Reversible Rotation
- Tight Speed Control within Rated Torque Range
- Effective Electronic Braking

P³ - Right Angle Reducer

- 20:1 Speed Reduction Ratio w/ Torque-Boost
- Single Shaft (Dual position & hollow shaft options)
- Up to 160 In-Lbf Torque at 17 RPM Output or;
- Up to 300 In-Lbf Torque at 3 RPM or Lower

**Automation
ControlsGroup**
Simplicity in Motion

Specifications

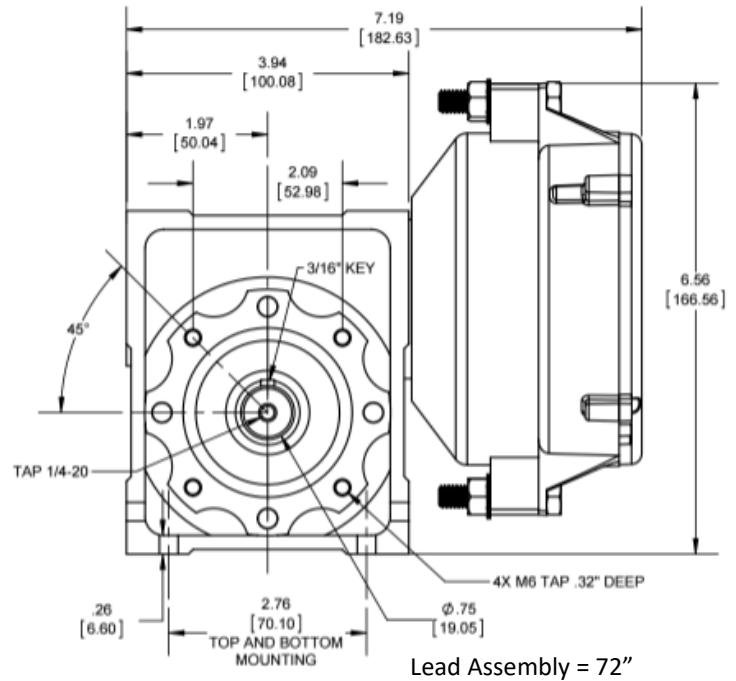
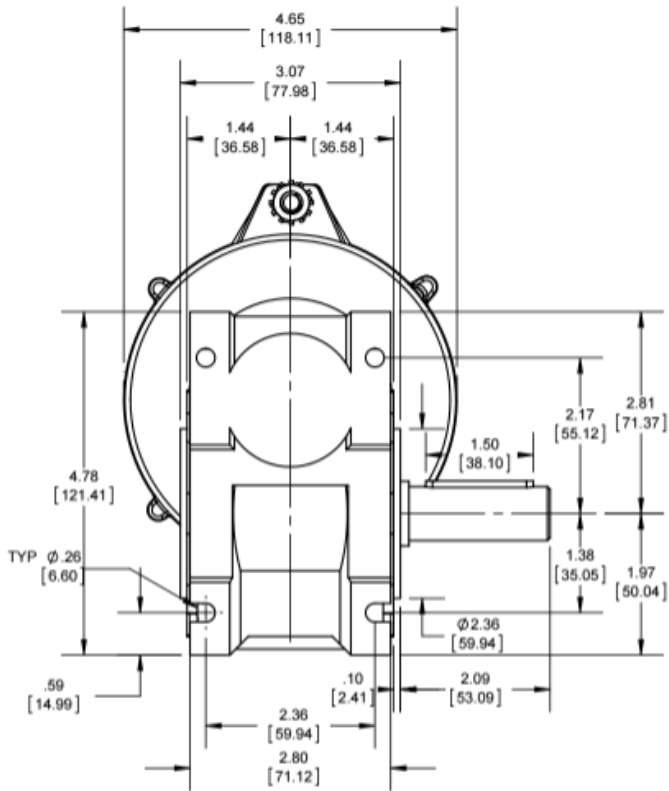

Quick Start Guide for Basic Motor Control

Controller: SCC-3 Hi Performance Model 110546

- Place DIP switch 3 in the ON position (slide switch to the right).
- On the 3-pin sensor connector, wire the sensor input (center pin) to the sensor "+" voltage (pin on the right).
- Apply 24VDC to the Slug input (I/O pin2 to start and stop the motor).
- When the Slug Input goes high then I/O pin 4 will go high to indicate the motor is running.

Quick Start Guide for Smart Conveyor Control Operation

Controller: SCC-3 Hi Performance Model 110546

- Using Switches 4-6 Set Your Desired Speed
- Set Switch 7 ON and Switch 8 OFF to Match the 125W24 Motor
- Connect the Motor Using the 8 Position Plug
- Connect Power and Ground (24 VDC)
- Using Switch 3 configure location (Exit or Entry zone)
- Using Switch 2 configure the operating mode (ZPA or ZIP)
- 24 VDC PNP input for start-stop

Model 110573

Speed Selection			
Switches			Output
6	5	4	RPM
Off	Off	Off	17
Off	Off	On	15
Off	On	Off	13
Off	On	On	11
On	Off	Off	9
On	Off	On	7
On	On	Off	5
On	On	On	3

Note: Motor speed can be controlled directly on the 110546 from 1-9 VDC or by using the 300128 speed control

(Refer to user manual for detailed set-up instructions)

For more information, contact:

Sales@AutomationControlsGroup.com

Telephone: (619) 677-6530